

MENABO

free time on the move

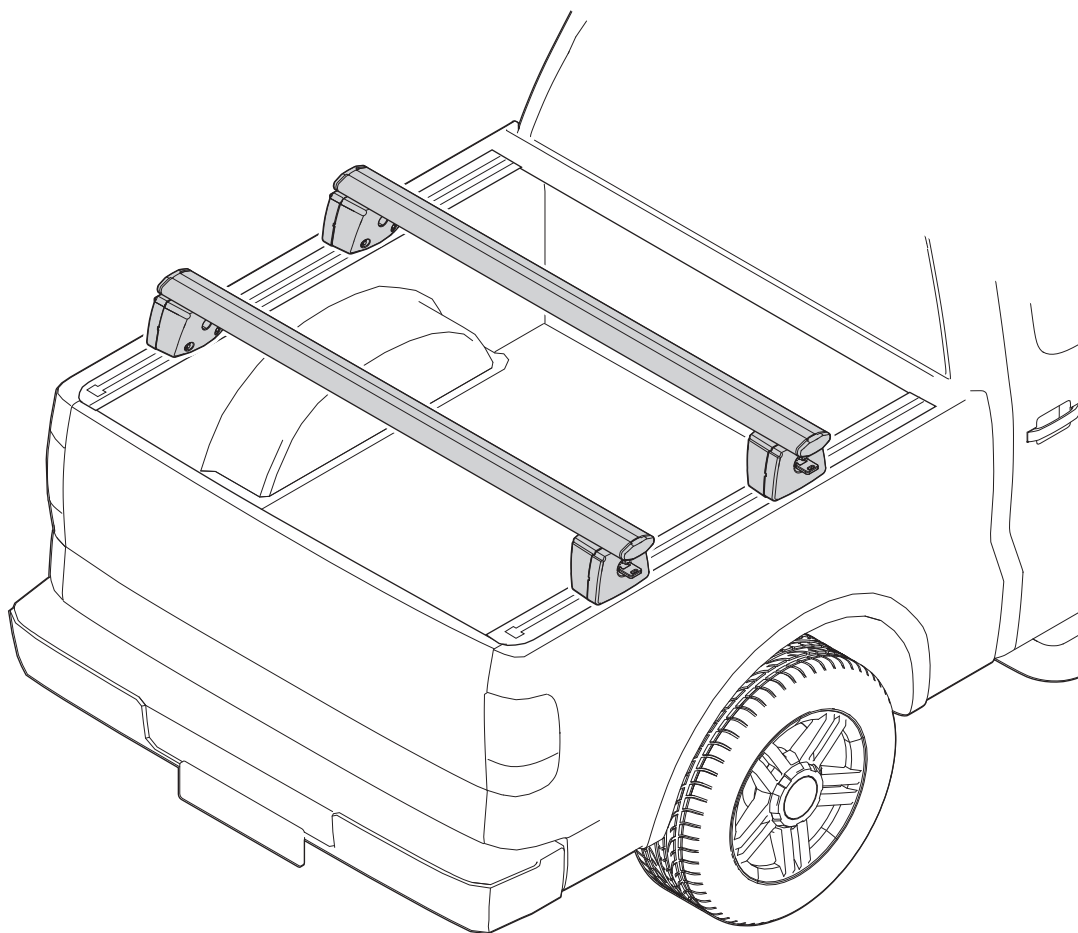

TRUCK BED RACK SYSTEM





IT Istruzioni di montaggio	ET Paigaldusjuhend	PT Instruções de Montagem
EN Fitting instructions	FI Asennusohje	RO Instrucțiuni de montare
DE Montageanleitung	HR Uputa za sastavljanje	RU Инструкции по установке
FR Instructions de montage	HU A felszerelés módja	SK Návod na montáž
ES Instrucciones de montaje	LT Pritvirtinimo instrukcijos	SL Navodila za pritrjevanje
BG инструкции за сглобяване	LV Stiprināšanas instrukcija	SV Monteringsanvisning
CS Návod na montáž	NL Instrukcja montażu	TK Uydurma talimat
DA Monteringsvejledning	NO Monteringsveiledning	ZH 裝修指導
EL Οδηγίες συναρμολόγησης	PL Instrukcja montażu	AR تعليمات التجميع



Made in Italy



N	[IT]Componenti (Inclusi) [EN]Components (Included) [FR]Composants (Comprises) [DE]Die Komponenten (im Lieferumfang enthalten) [ES]Componentes (Incluido)	Q
1		2
2		2
3	 L 5mm - 0.2"	1

N	[IT]Ricambi (A Richiesta) [EN]Spare Parts (Made to order) [FR]Pièces de rechange (Sur commande) [DE]E Teile (auf Anfrage) [ES]Piezas de recambio (Previa solicitud)	Q	Codice-Code-Código
2		2	700045000000
3	 L 5mm/0.2"	1	700025000000
A		4	700045100000
B		4	000084800000

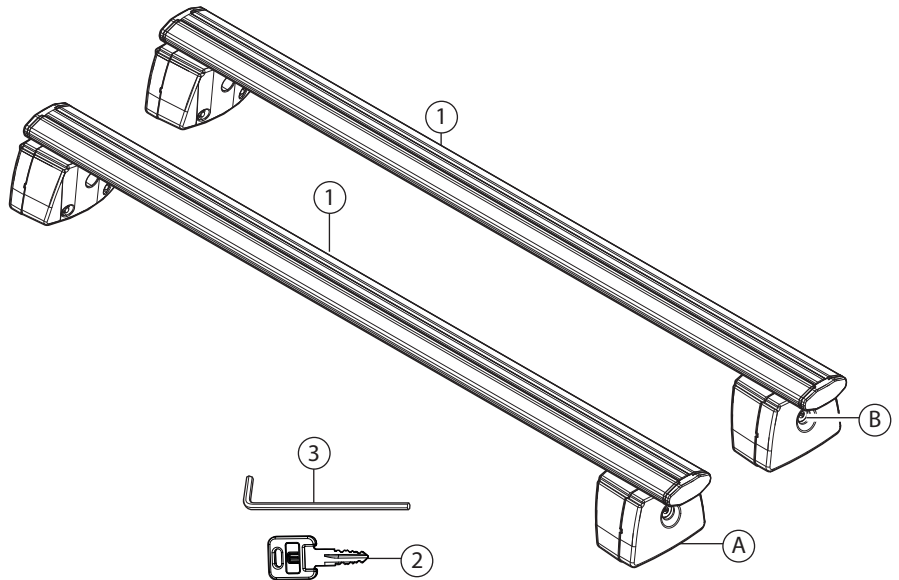

EN) Truck Bed Rack System bars can be installed only on vehicles with beds equipped with "T" grooves. Should the vehicle not meet this requirement, it is possible to purchase the special structure available in different lengths.

FR) Le Truck Bed Rack System ne peut être installé que sur des véhicules dotés de carrosseries à rainures en T. Si votre véhicule ne répond pas à cette exigence, vous pouvez acheter le cadre de montage disponible en différentes longueurs.

ES) El sistema Truck Bed Rack System sólo puede instalarse en vehículos con cajón con ranuras en T. Si su vehículo no cumple este requisito, puede adquirir el marco de instalación disponible en diferentes longitudes.

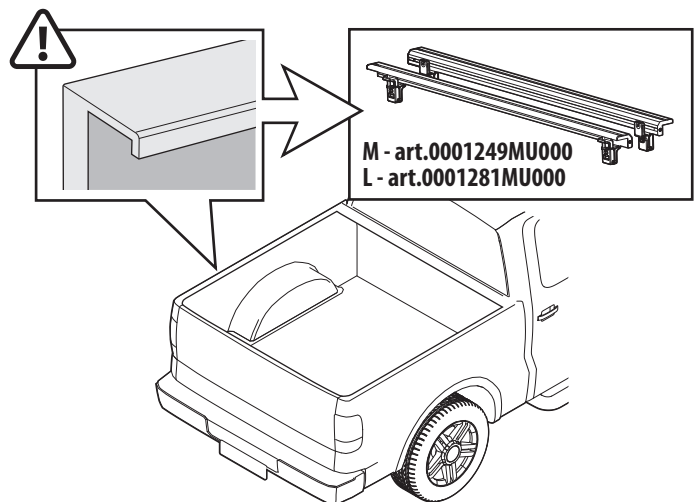
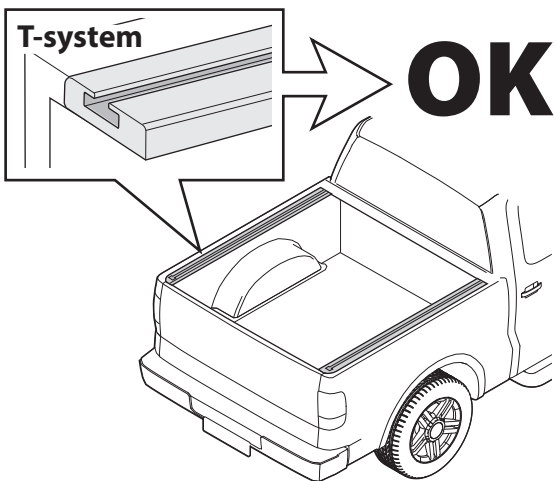

x4

1

EN) Insert key, open lock and remove front cover of foot kit.

FR) Insérez la clé, ouvrez la serrure et retirez le couvercle avant du kit de pied.

ES) Introduzca la llave, abra la cerradura y retire la tapa frontal del juego de pies.

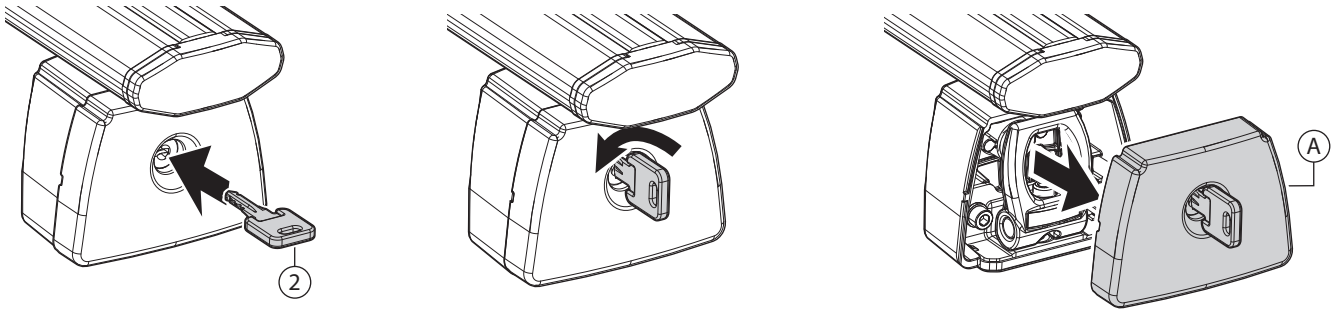

2

EN) Loosen the screw shown in the figure.

FR) Desserrez la vis indiquée sur la figure.

ES) Afloje el tornillo mostrado en la figura.

EN) Position the bars on the bed by inserting the "T" screw's head inside the groove.

FR) Positionnez les barres sur le lit en insérant la tête de la vis en "T" dans la rainure.

ES) Coloque las barras en la caja introduciendo la cabeza del tornillo "T" en la ranura.

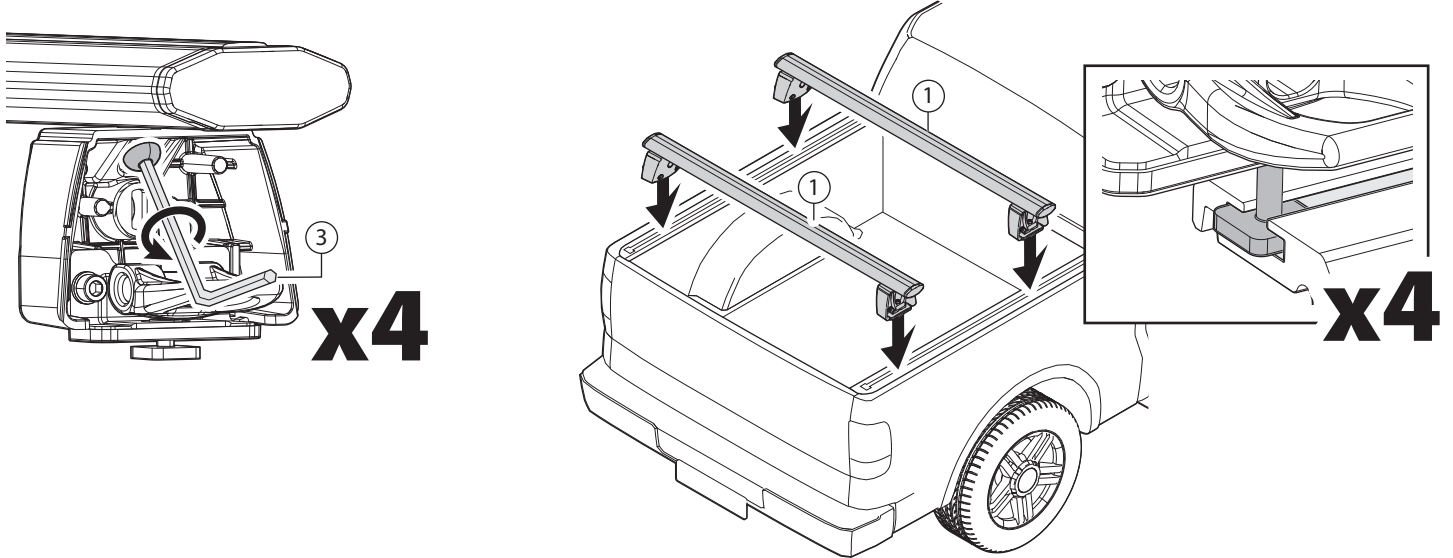

3

EN) Position the profiles equidistant from the foot kits.

FR) Positionnez les profiles à équidistance des kits de pieds.

ES) Coloque los profiles equidistantes de los kits de pies.

EN) Tighten the screw to fix the profiles.

FR) Serrez la vis pour fixer les profiles

ES) Apriete el tornillo para asegurar los profiles.

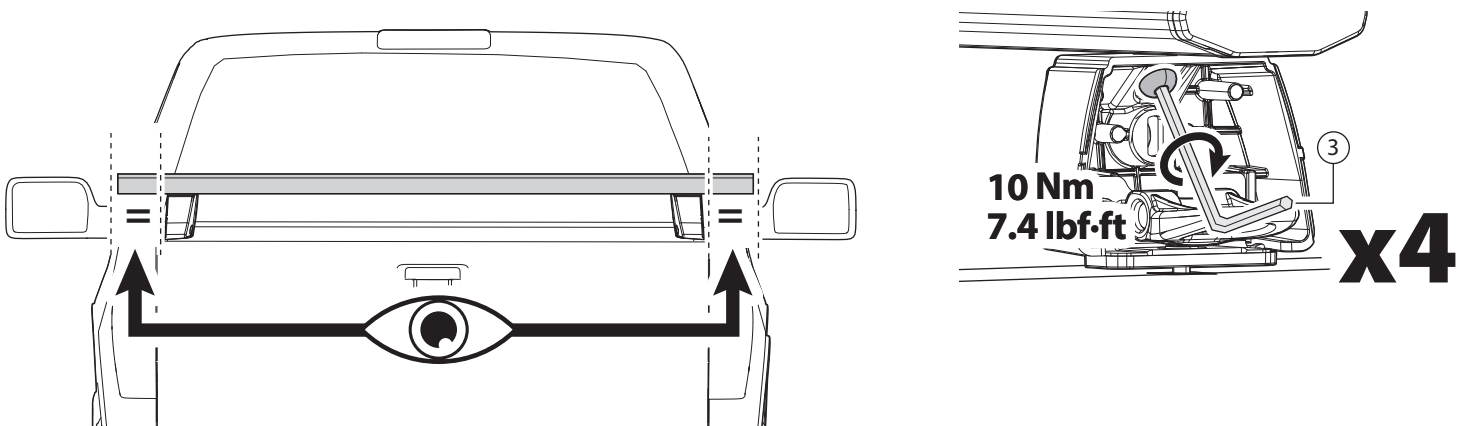

- EN) (a) Turn center pin clockwise to tighten the "T"screw.
 (b) Close the lever.
 (c) Test the assembly by moving the bars sideways. If the bars are unstable, repeat steps (A) and (B) by tightening the "T" screw more. If the bars remain stable and firm, proceed to the next step.
- FR) (a) Tournez la goupille centrale dans le sens des aiguilles d'une montre pour serrer la vis en "T".
 (b) Fermez le levier.
 (c) Testez l'assemblage en déplaçant les barres latéralement. S'ils sont instables, répétez les étapes (A) et (B) en serrant davantage la vis en "T". Si les barres restent stables et fermes, passez à l'étape suivante.
- ES) a) Gire el pasador central en el sentido de las agujas del reloj para apretar el tornillo en "T".
 b) Cierre la palanca.
 (c) Pruebe el montaje moviendo las barras lateralmente. Si son inestables, repita los pasos (A) y (B) apretando más el tornillo en "T". Si las barras permanecen estables y firmes, pase al siguiente paso.

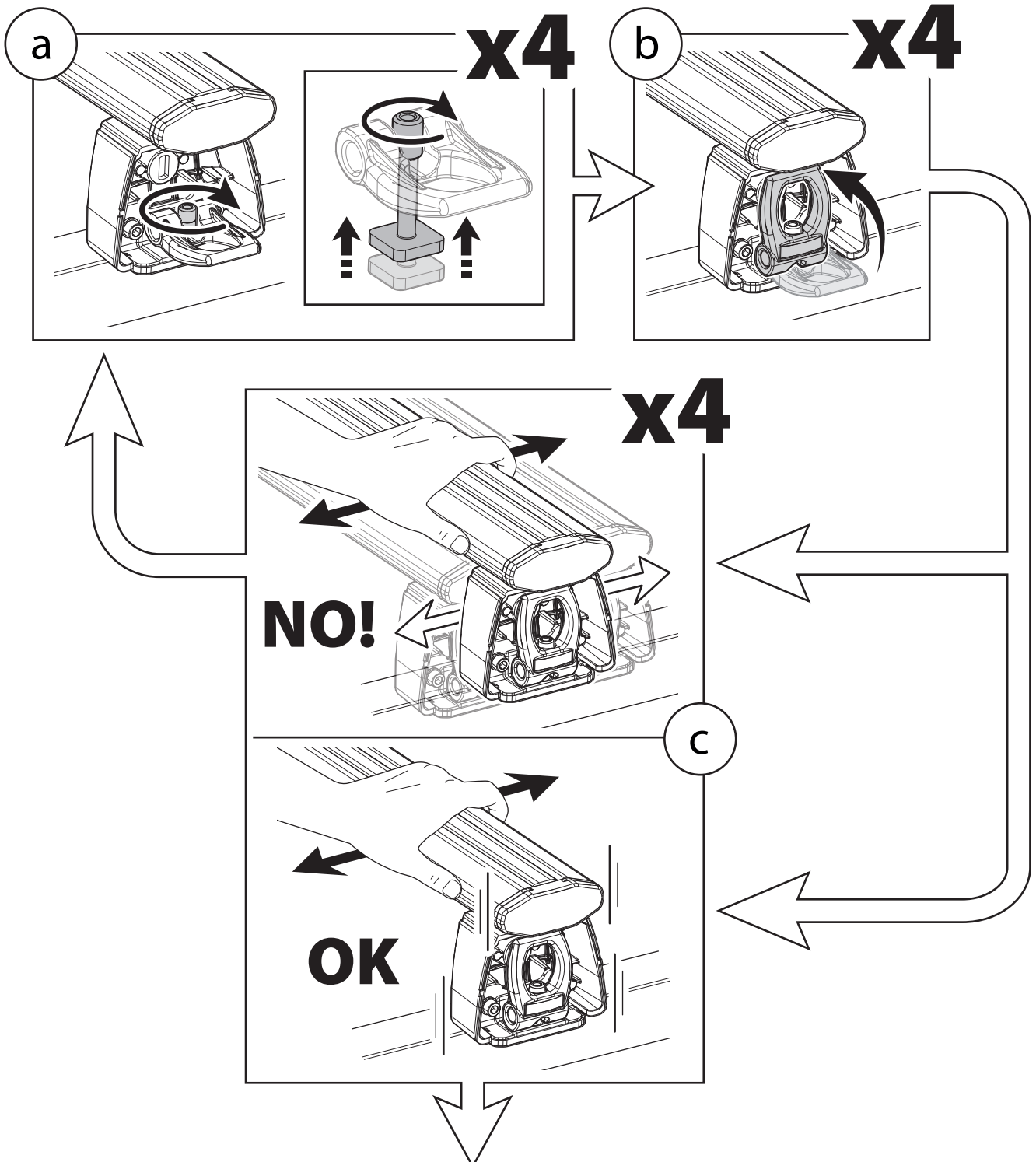

5

EN) Place the front cover on the foot kit, close the lock and remove the key.

FR) Insérez le couvercle frontal, fermez et retirez la clé.

ES) Introduzca la tapa frontal, cierre y retire la llave.

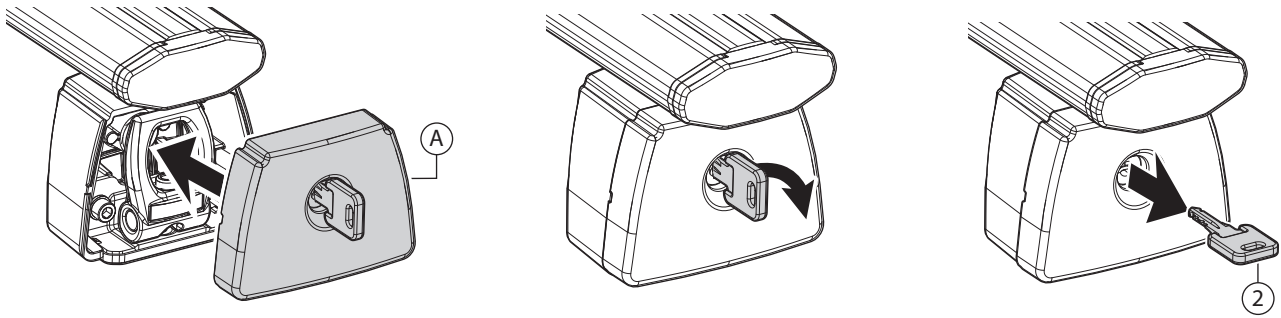
**6**

EN) When not in use, the bars can be quickly moved by sliding them towards the rear panel of the pickup truck. To loosen the fastening, lift the lever and turn the central pin counterclockwise.

FR) Lorsqu'elles ne sont pas utilisées, les barres peuvent être déplacées rapidement en les faisant glisser vers la fin du lit de la camionnette. Pour desserrer la fixation, ouvrez le levier et tournez la goupille centrale dans le sens inverse des aiguilles d'une montre.

ES) Cuando no se utilizan, las barras se pueden mover rápidamente deslizándolas hacia el final del cajón de la camioneta. Para aflojar la fijación, abra la palanca y gire el pasador central en sentido contrario a las agujas del reloj.

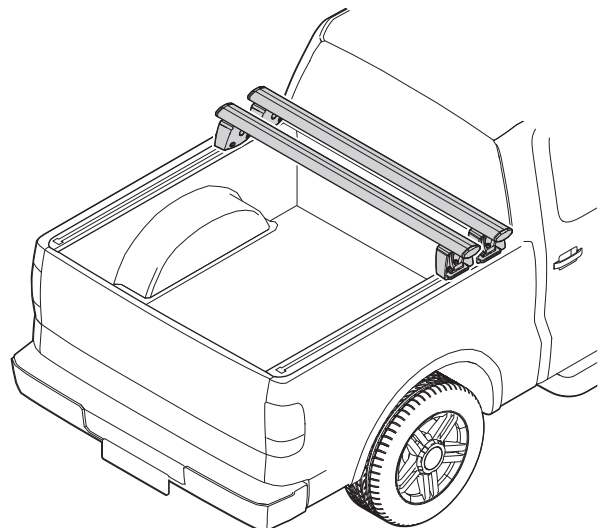
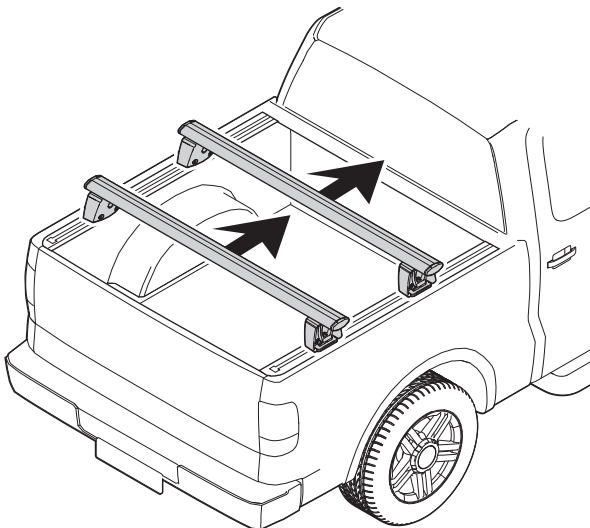
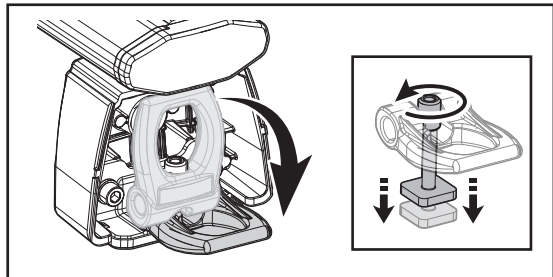
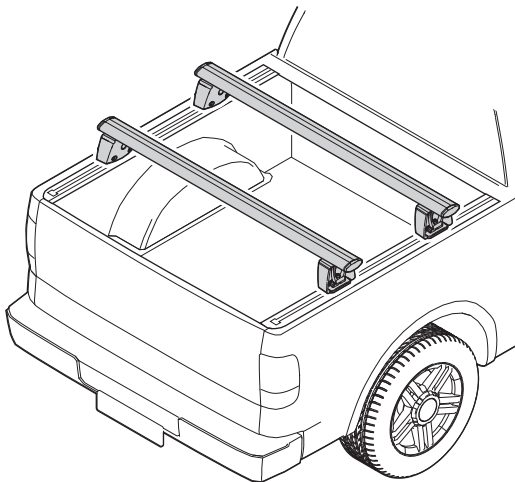



**MAX
LOADING =**

4,6kg
10lb

+

90kg/198lb

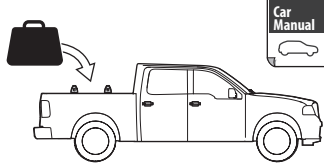
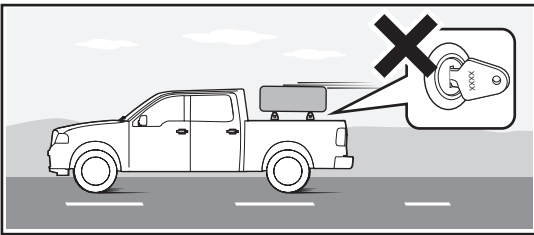
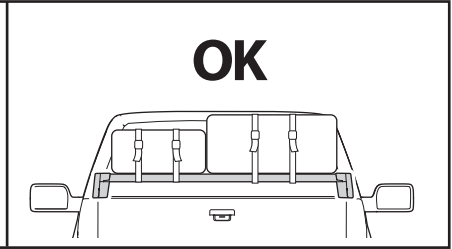
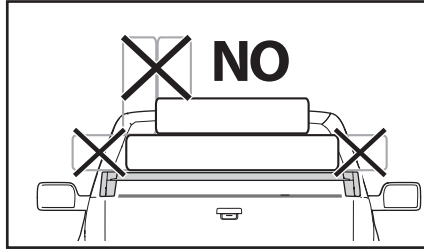
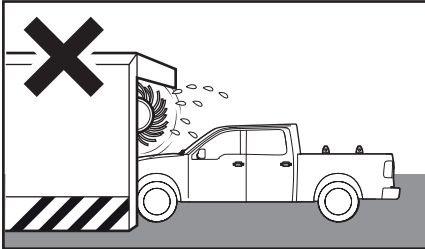
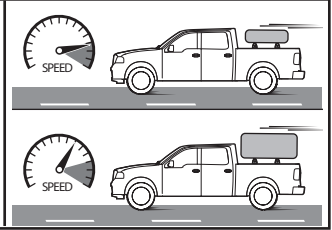
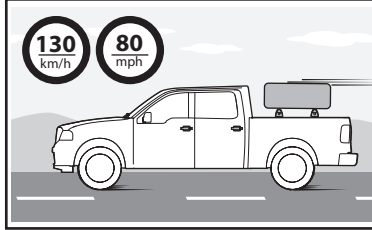
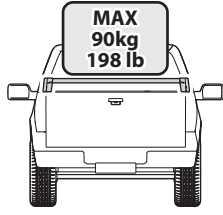

Truck bed rack system

4,6kg / 10 lb

MAX 90kg / 198 lb



F.lli Menabò S.r.l.
Via 8 Marzo, 3 -Z.I. Corte Tegge
42025 Cavriago (RE) ITALY

MENABO USA INC.
18 Bridge Street, Unit 2A
Brooklyn, NY, 11201 - U.S.A.

MENABO CANADA INC.
1710 TransCanada Hwy
Dorval, QC, H9P 1H7 - Canada

customercare@fli-menabo.it
customercare@menaboamericas.com
www.menabocaraccessories.com

Product registration EU:

- IT) eu.menabocaraccessories.com/ita/product-support-ita
- EN) eu.menabocaraccessories.com/eng/product-support-eng
- DE) eu.menabocaraccessories.com/deu/product-support-deu
- FR) eu.menabocaraccessories.com/fra/product-support-fra
- ES) eu.menabocaraccessories.com/esp/product-support-esp

Product registration Americas:

- EN) america.menabocaraccessories.com/en/product-support
- FR) america.menabocaraccessories.com/fr/support-produit
- ES) america.menabocaraccessories.com/es/soporte-de-producto

Cod.Istr.	500037700000
Data	01/09/2021

www.menabocaraccessories.com

Name

Surname

Email

Telephone

Serial number

Product name

Sign in